

1. SNAP THE X-CLIP III TO NEX PIPE

2. TURN THE X-CLIP III DOWN

3. MAKE SURE THE RUBBER FOOT OF X-CLIP III ENGAGES ROOF PANEL AND TIGHTEN THE SCREW

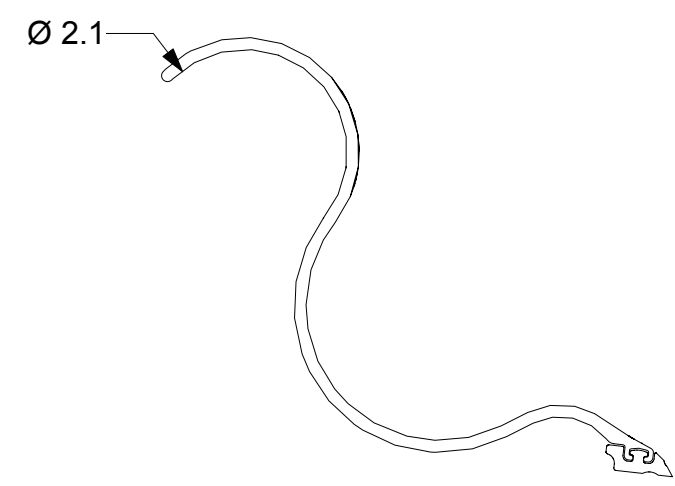
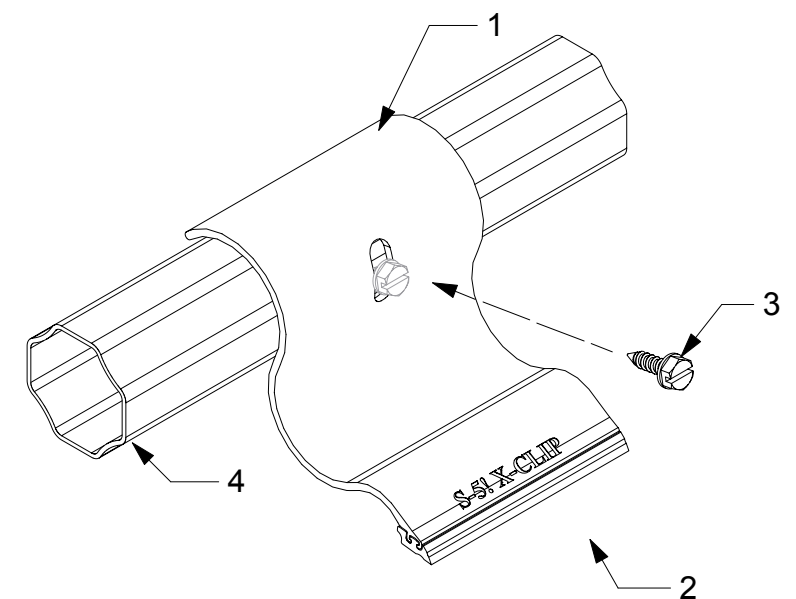
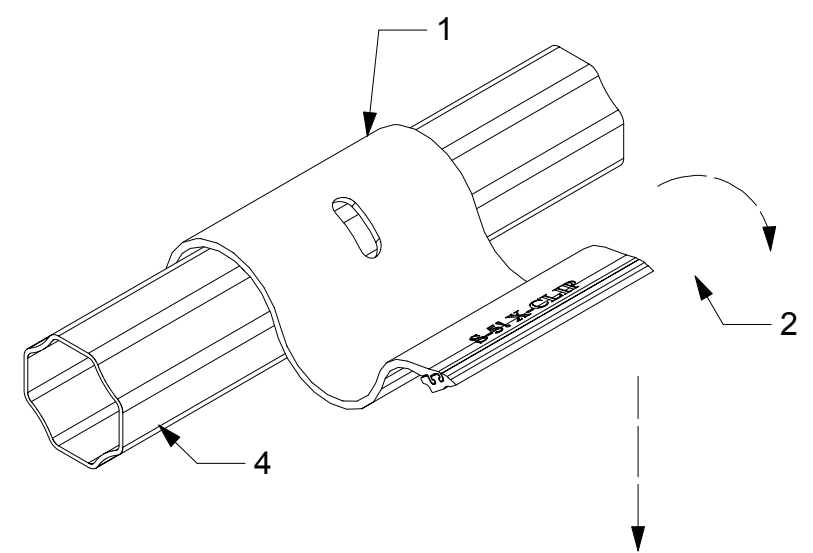
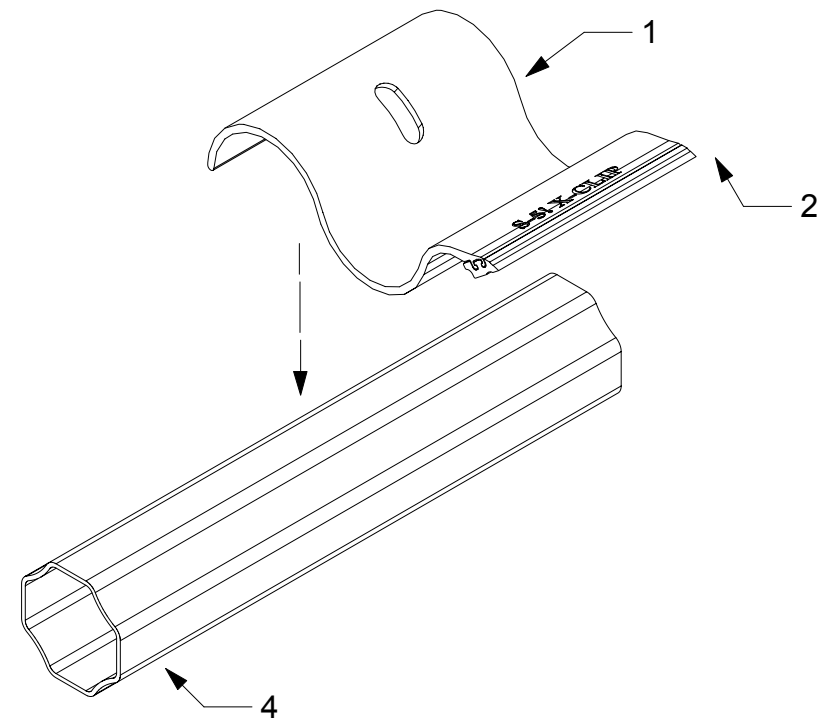

- Notes**
1. X-CLIP III
 2. RUBBER FOOT "TOE"
 3. #14 x 7/8" STAINLESS SELF-DRILLING SCREW
 4. NEX PIPE CROSSMEMBER
 5. XGARD
 6. M10 STAINLESS HEX FLANGE BOLT
 7. TOP OF THE SEAM

MATERIAL:	6000 SERIES AL		
EST ASSEMBLY WEIGHT :			
SUPPLIED HARDWARE:			
SCALE:	1:2.25		
OTHER:			



METAL ROOF INNOVATIONS, LTD.
 8655 TABLE BUTTE RD
 COLORADO SPRINGS, CO 80908
 719-495-0518
 719-495-0045 (FAX)

TITLE				X-Clip III	
DRAWING NO.	XC3-A CCD	DRAWN BY	DMH	DATE	06/27/2014
<small>S-5!® PRODUCTS ARE PROTECTED BY MULTIPLE U.S. PATENTS INCLUDING 5,228,248, 5,983,588 AND 6,164,033 (OTHERS ISSUED AND PENDING). EUROPEAN PATENTS ARE ALSO APPLIED FOR AND PENDING UNDER THE PATENT COOPERATION TREATY WITH DIVISIONAL FILING RIGHTS RETAINED. METAL ROOF INNOVATIONS, LTD. (LICENSOR OF S-5!® TECHNOLOGY) AGGRESSIVELY PROSECUTES PATENT INFRINGEMENT.</small>					